



akustikmiljö

BETTER LOOKING SOUND

S

GB

Gardiner Curtains

Innehåll

Content

Wave

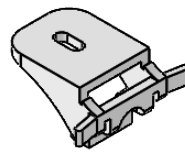
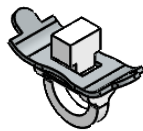
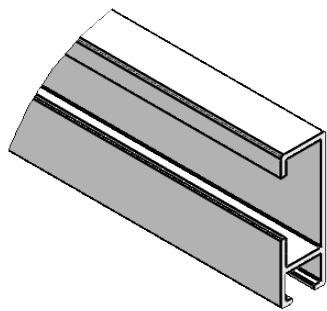

Alt.

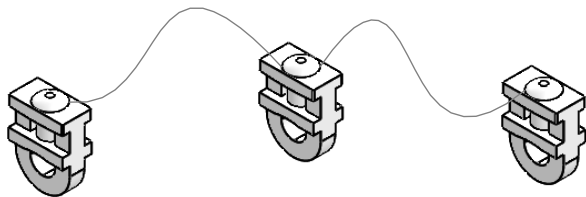
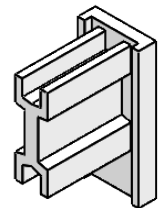
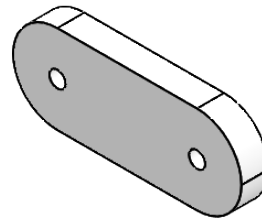
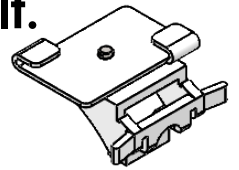

Antal ingående komponenter beror på hur lång skenan är

The number of components depends on how long the rail is

Glidband Sliding curtain

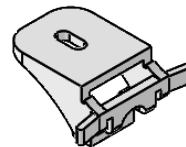
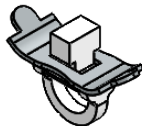
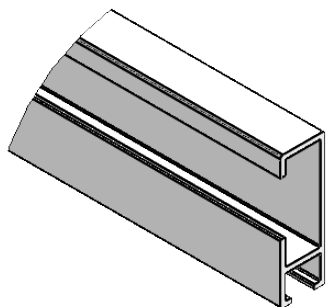

Alt.

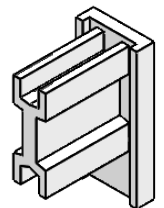
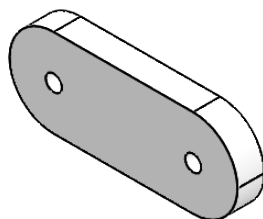
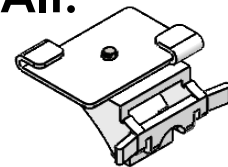

Veckband Pleat curtain

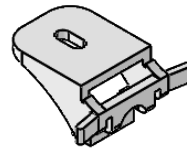
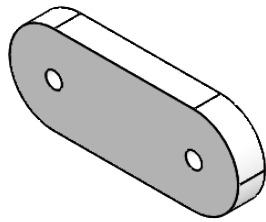
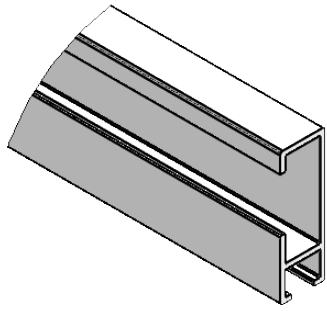

Alt.

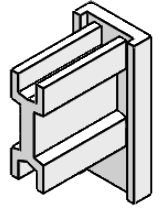
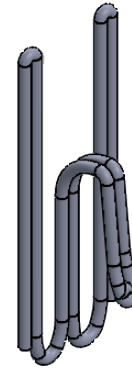
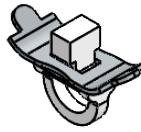
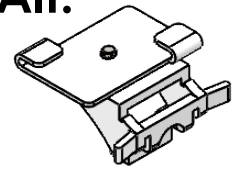

Antal ingående komponenter beror på hur lång skenan är

The number of components depends on how long the rail is

Panel Panel curtain

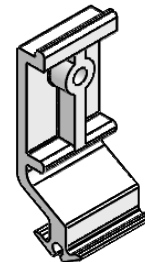
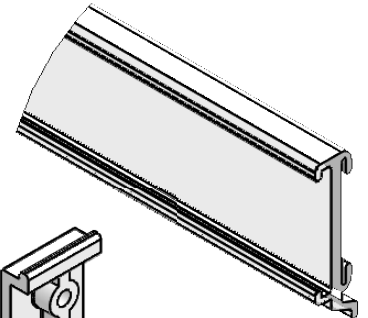
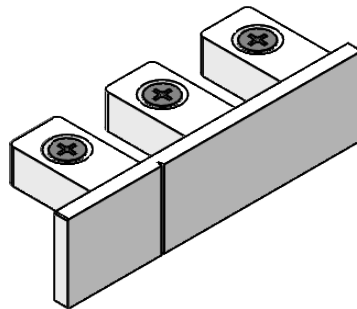
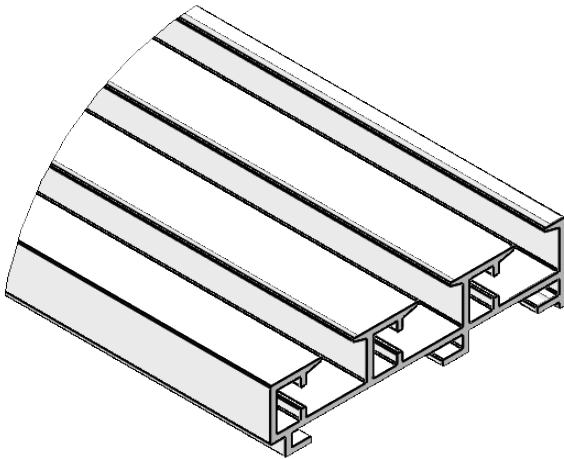

Tips WAVE, Vanligaste upphängningen (Dubbel veckning)

1. Lägg ut gardinen på bordet.
2. Dra ut gliden i skenan för att se att de täcker det område du vill att de ska täcka. Så att det inte är för lite glid om man ska täcka hela skenan. Räkna antal glid i skenan, jämt antal är bäst för att sluta och börja med en våg utåt.
3. Se till att det blir samma antal krokar som glid i gardinen.
4. Kroka gardinen i var 8:e ficka. Detta kan ändras om du behöver få in eller ta bort något för att passa skenan. Det går då bra att kroka några var 7:e eller var 9:e så det blir jämt antal.
5. Gardinen ska vara varannan våg in och varannan ut, dvs mellan första två gliden drar du ut vågen, mellan nästa två drar du in vågen.

Tips WAVE, the most common suspension (double folding)

1. Place the curtain on the table.
2. Pull out the slider from the rail to see that it covers the area you want it to cover, making sure that there isn't too little slide if you want to cover the whole rail. Count the number of slides in the rail; an even amount is the best to start and finish with a fold outwards.
3. Make sure there is the same amount of hooks as sliders in the curtain.
4. Hook the curtain in every 8th pocket. This can be changed if you need to add or remove any to fit the rail. You can then hook each 7th or 8th to make it an even amount.
5. The curtain should have every other fold inwards and every other fold outwards, meaning that you pull the fold out between the first two sliders and pull the fold in between the next two.

Tips VECKBAND, vanligaste upphängningen (veckning 75%)

1. Trä första fingret på kroken i första fickan på veckbandet, med kroken mot dig.
2. Andra fingret trär du i nästa ficka på veckband. Hoppa över en ficka mellan krokarna. För att få glesare veckning, lämna två fickor, för tätare krokning lämna ingen ficka mellan krokarna.
3. Fördela fingerkrokarna jämnt över gardinens bredd.
4. Om det är för mycket glid i skenan kan du dölja dessa mellan krokarna.

Tips FOLDING STRIP, the most common suspension (folding 75%)

1. Thread your first finger on the hook in the first pocket of the folding strip, with the hook towards you.
2. Skip one pocket and then thread your second finger in the next pocket of the folding strip. For sparser folding, skip two pockets and for tighter folding, skip no pockets.
3. Distribute the finger hooks evenly over the curtain's width.
4. If there is too much glide in the rail you can cover them between the hooks.

Tips SYDDA GLID/GLID BAND (välj veckning)

1. Trä på gardinen på skenan, då gliden sitter fast på gardinen.
Ta bort glid om det finns i skenan.

Tips SEWN SLIDERS / SLIDING STRIPS (choose folding)

1. Thread the curtain on the rail as the slider is attached to the curtain.
Remove the slider if it's already mounted on the rail.